

## Technical specification

# MOBY 3200

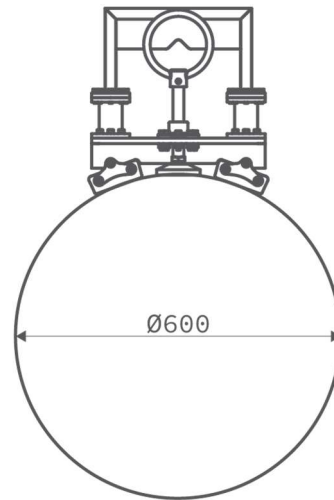
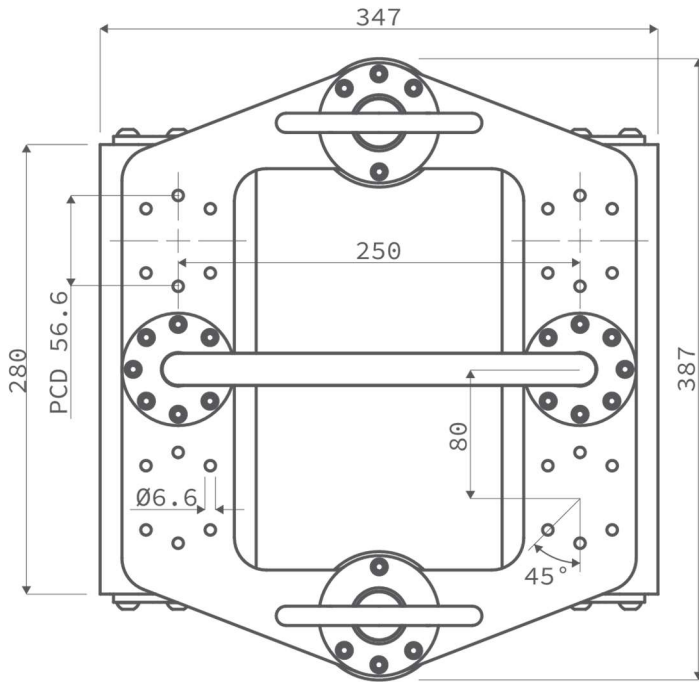

Weight	24.5 kg
Holding force <sup>1</sup>	3200 kg
Min. diameter of tubular surface	600 mm

<sup>1</sup>Measured perpendicularly on a 20 mm mild steel plate

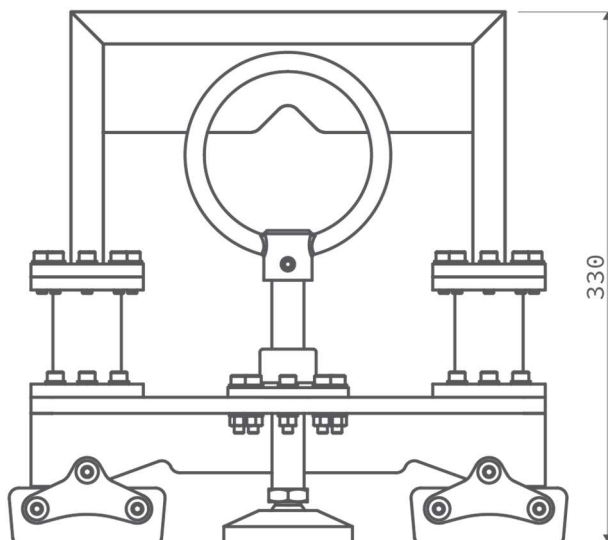

Part	Material
Magnet housing	316L
Tool plate	316L
Grip bar	316L
Fasteners	316L
Release mechanism (male threads and ring)	316L
Release mechanism (female threads)	Alu bronze
Magnetic elements (encapsulated)	NdFeB N42
Conductive elements	430

## BLUMAGS

Blumags by Apex Technology AS  
 Oslo, Norway  
 Org. No. 924 362 170  
[hi@blumags.com](mailto:hi@blumags.com)  
[www.blumags.com](http://www.blumags.com)